

This drawing is provisional and subject to our reconfirmation and/or revision without notice.

Coordinates			
記号	X	Y	R
GM	0	0	—
DH1	-15200	-5300	—
DH2	15200	5300	—
b1	3092	16654	320
b2	-16920	800	320
b3	-16920	-800	320
b4	-800	-16920	320
b5	800	-16920	320
b6	16920	-800	320
b7	16920	800	320

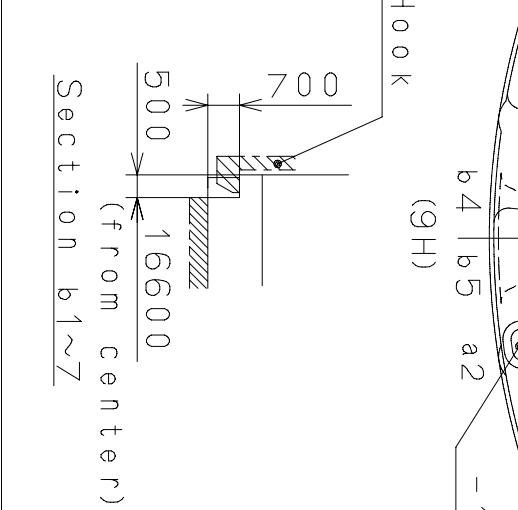
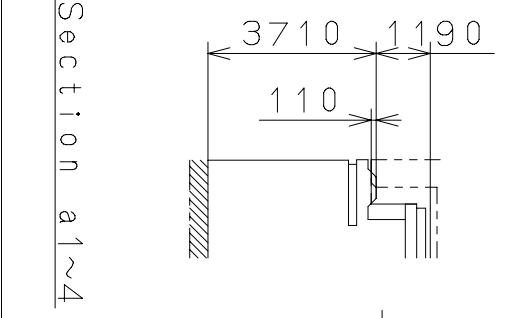
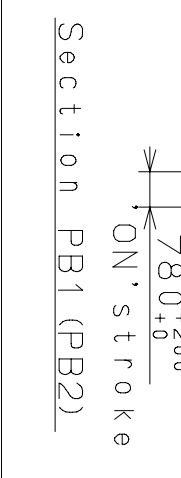
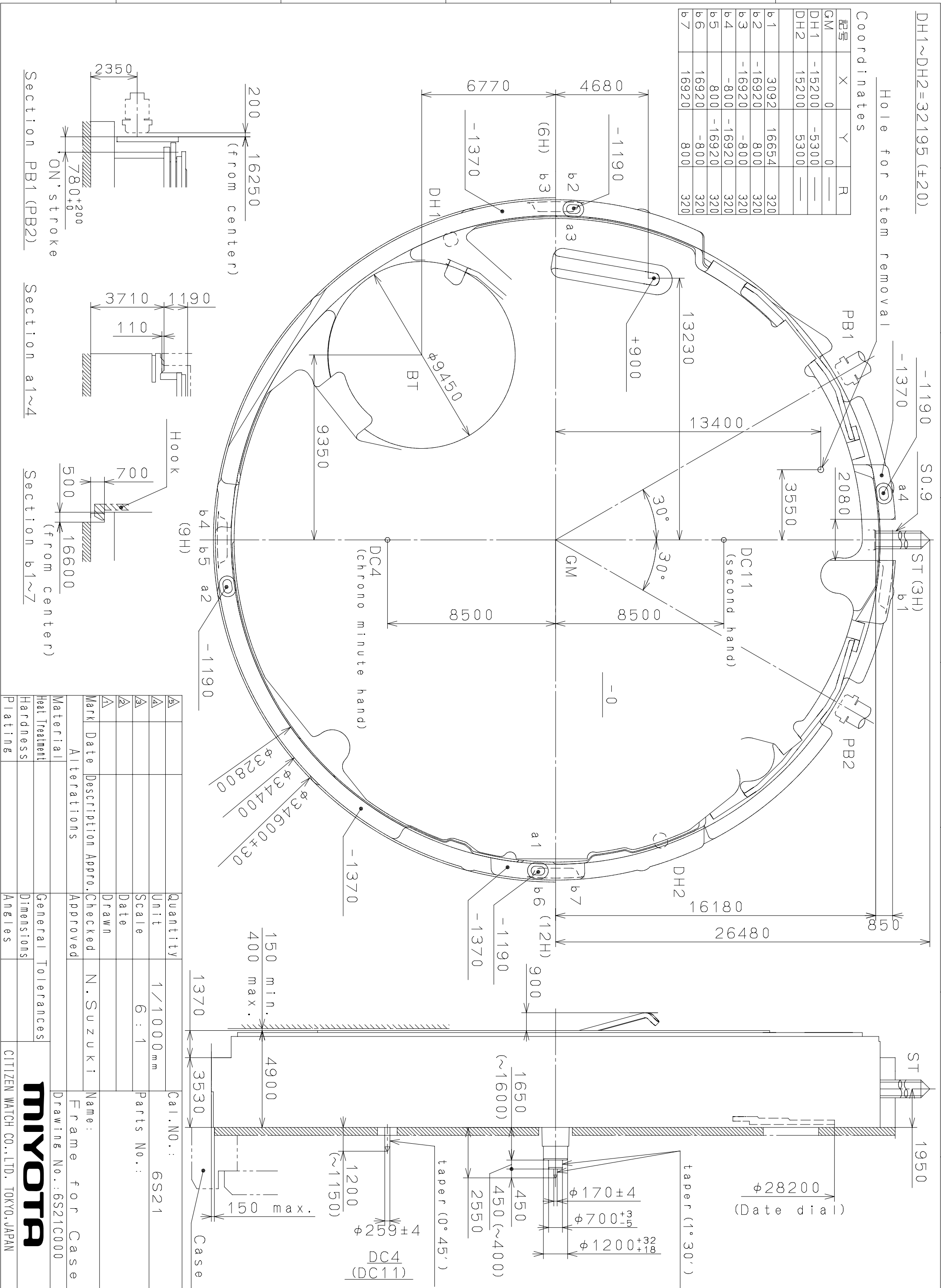

Mark	Date	Description	Appr.	Checked	Drawn	Name:
Alterations			Approved			N. Suzuki

Material	Heat Treatment	Hardness	Plating

Quantity	Unit	Cal. NO.:
1	1/1000 mm	6S211

Scale	Parts No.:
6 : 1	

Material	General Tolerances

Material	Dimensions	Angles

MIYOTA
CITIZEN WATCH CO., LTD. TOKYO, JAPAN

Frame for Case
Drawing No.: 6S21C000

2011/11/10 (15:19:04)

This drawing is provisional and subject to our reconfirmation and/or revision without notice.

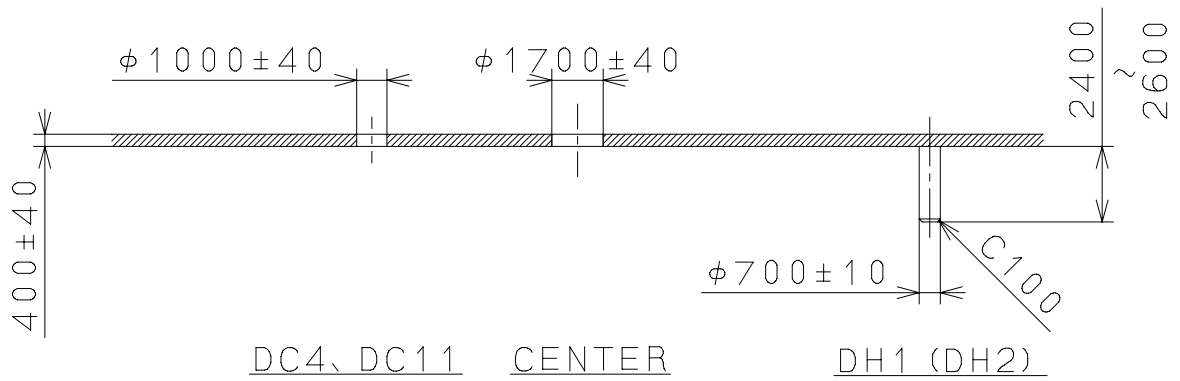
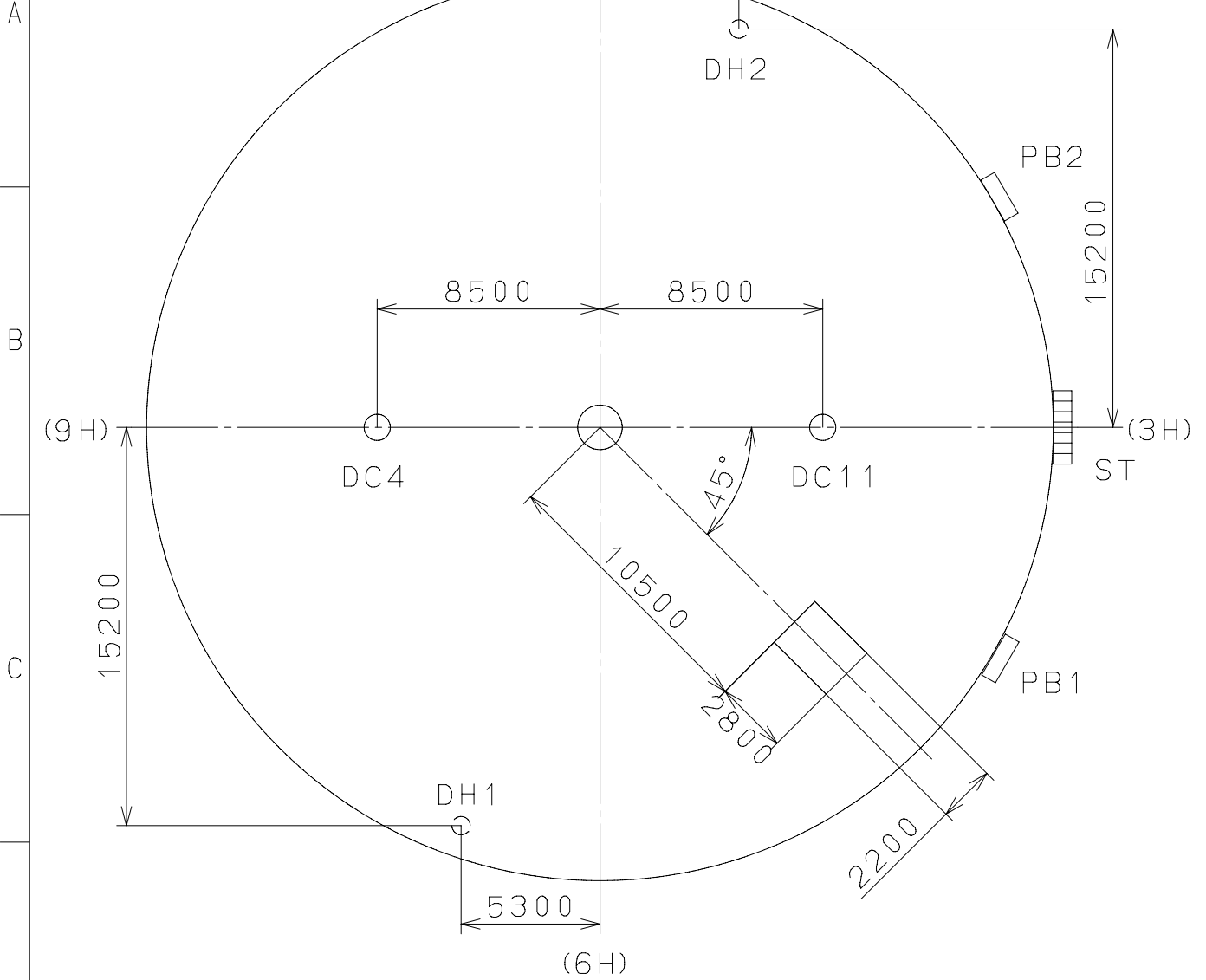

△			Quantity		Cal.NO.:
△			Unit	1 / 1000 mm	6S21-00A
△			Scale	4 : 1	Parts No.:
△			Date		
△			Drawn		
Mark	Date	Description	Appr.	Checked	Name:
		Alterations	Approved	N. Suzuki	Indications for Dial
Material					Drawing No.: 6S21D000
Heat Treatment			General Tolerances		MIYOTA
Hardness			Dimensions		
Plating			Angles		
					CITIZEN WATCH CO., LTD. TOKYO, JAPAN

2010/07/26 (09:03:08)

This drawing is provisional and subject to our reconfirmation and/or revision without notice.

A
B
C
D
E
F

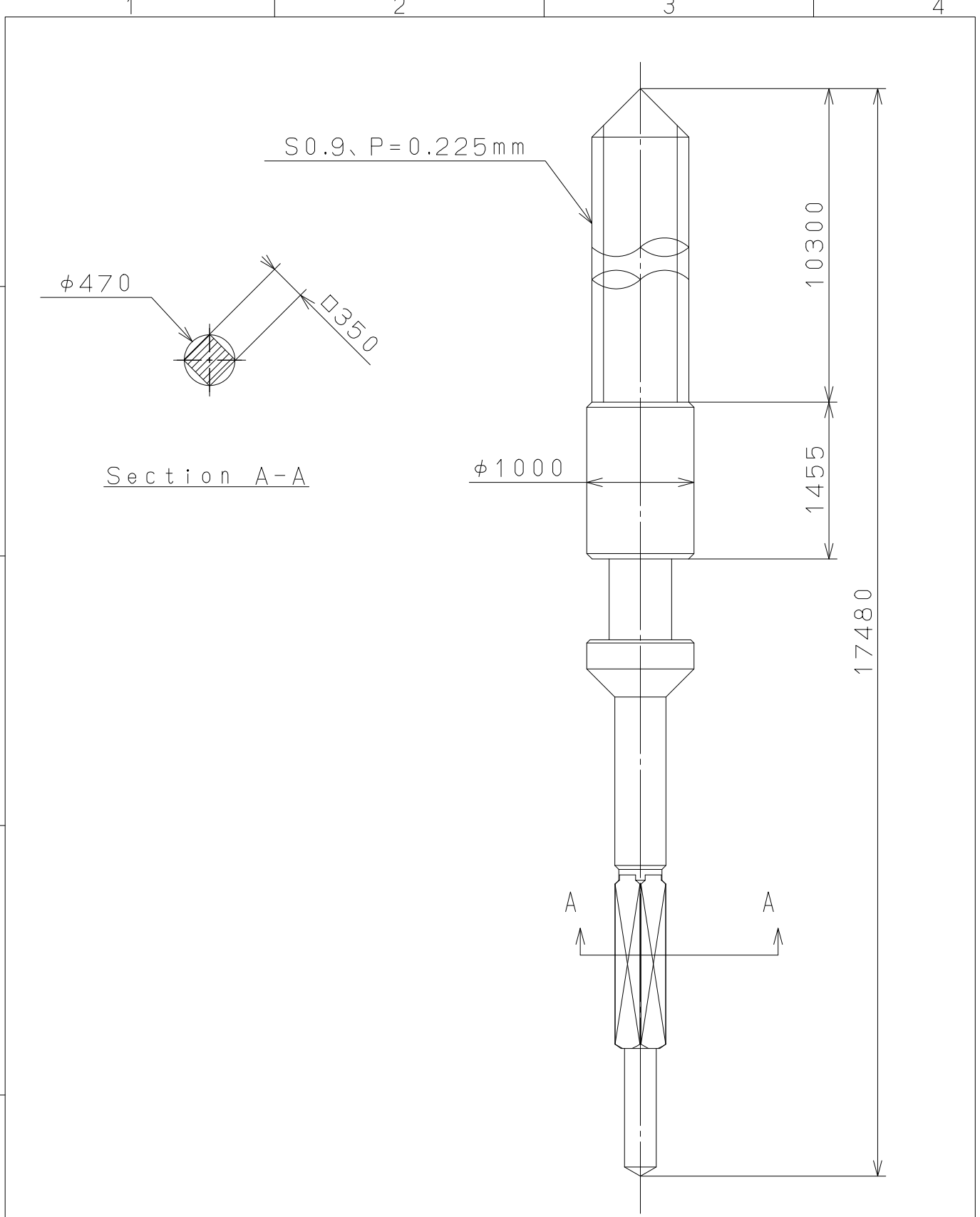

△5			Quantity		Cal.NO.:
△4			Unit	1/1000mm	
△3			Scale	20:1	Parts No.:
△2			Date		065-A13
△1			Drawn		
Mark	Date	Description	Appro.	Checked	Name:
		Alterations	Approved	N. Suzuki	SETTING STEM
Material					Drawing No.: A130S000
Heat Treatment			General Tolerances		
Hardness			Dimensions		
Plating			Angles		
				CITIZEN WATCH CO., LTD. TOKYO, JAPAN	